

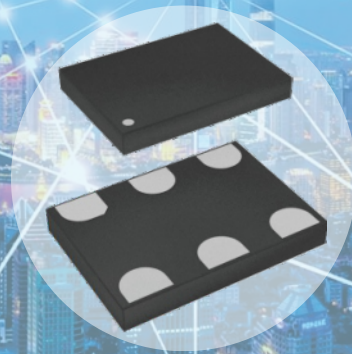

深圳市晶科鑫实业有限公司

SHENZHEN CRYSTAL TECHNOLOGY INDUSTRIAL CO.,LTD

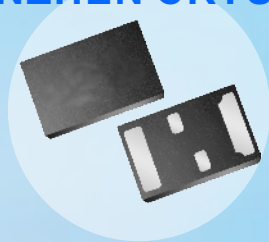

Web: <https://www.q-crystal.com>

E-mail: sjk@q-crystal.com

Tel: (86)+755-88352869

MEMS Oscillator

Fast Delivery

32.768 kHz Oscillator	2
SJK1508 Series 1.5*0.8 Size 32.768kHz Oscillator	2
SJK1632 Series 2.0*1.2 Size 32.768kHz Oscillator	4
Low Power Programmable Oscillator	6
SJK8008 Series SMD Programmable Oscillator	6
SJK8009 Series SMD Programmable Oscillator	7
Dimensions	8
LVPECL /LVDS Programmable Oscillator	9
SJK9120 Series SMD LVDS Programmable Oscillator	9
SJK9120 Series SMD LVPECL Programmable Oscillator	10
SJK9121 Series SMD LVDS Programmable Oscillator	11
SJK9121 Series SMD LVPECL Programmable Oscillator	12
Dimensions	13
High Temperature Programmable Oscillator	14
SJK8918 Series SMD High Temperature Oscillator	14

SJK1532 32.768kHz MEMS Oscillator



32.768kHz MEMS Oscillators

Ultra-Low Power, Ultra-Small

Features

- Smallest package size: 1.5 × 0.8 mm
- <10 ppm frequency tolerance
- Ultra-low power: <1 μ A
- Oscillator output eliminates external load caps
- Directly interfaces to XTAL inputs
- Vdd supply voltage: 1.5V~3.63V
- Automatic mounting and reflow soldering
- Applications: Mobile phone, Watches, Tables, RTC reference clock, PC, etc.
- RoHS Compliant /Pb Free

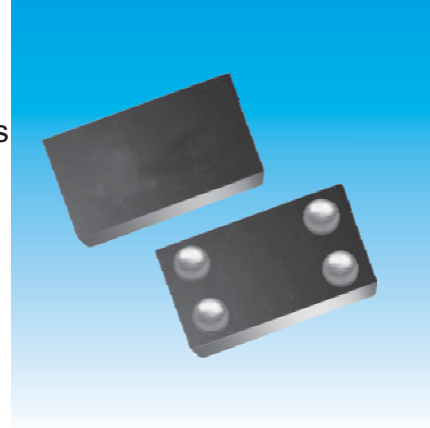

Standard Specification

Item /Type	SJK1532
Frequency	32.768kHz
Output Type	LVC MOS /nano Drive
Initial Tolerance	10ppm Max.
Frequency Stability	± 75 ppm~ ± 250 ppm
Operating Supply Voltage	1.2V~3.63V
Core Operating Current	0.9 μ A Max.
Output Stage Operating Current	0.125 μ A /Vp-p
Power-supply Ramp	100ms Max.
Start-up Time at Power-up	180ms Typ.
Commercial Temperature	-10~+70°C
Industrial Temperature	-40~+85°C
Output Rise/Fall Time	200ns Max.
Output Clock Duty Cycle	48~52%
Voltage Vol (Max.) /Voh (Min.)	10%Vdd /90%Vdd
Maximum Output Drive	50pF Max.
Period Jitter	35ns Typ.
Storage Temperature	-65~+165°C
Aging (at 25°C)	± 1 ppm at First Year
Packing Unit	3000pcs./reel

Pin Functions

Top View

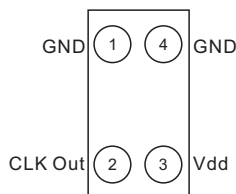

Pin Connections

Pin No.	Connection
1	GND
2	CLK Out
3	Vdd
4	GND

SJK1532 32.768kHz MEMS Oscillator



32.768kHz MEMS Oscillators

Ultra-Low Power, Ultra-Small

Dimensions [mm]

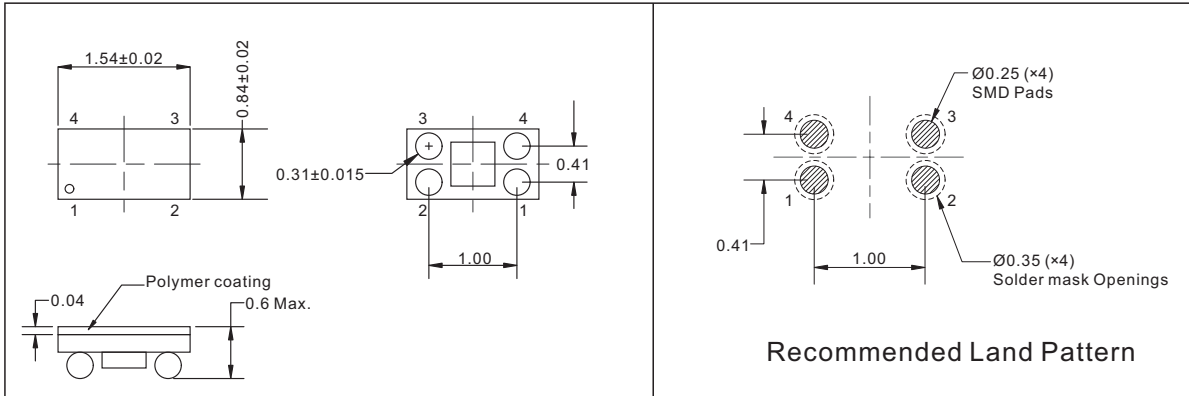

Features

- <20ppm initial tolerance
- <100ppm stability over -40~+85°C
- Small size package: 2.0×1.2mm
- SOT23-5 package option for industrial and automotive applications
- Ultra-low power: 1.0μW
- Vdd supply voltage: 1.5V~3.63V
- Wide operating temperature range options
- Automatic mounting and reflow soldering
- Applications: RTC reference clock, WiFi, Bluetooth modules, etc.
- RoHS Compliant /Pb Free

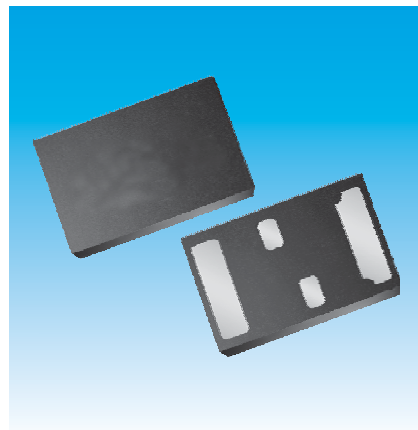

Standard Specification

Item /Type	SJK1630
Frequency	32.768kHz /16.384kHz
Supply Voltage	1.5V~3.63V
Initial Tolerance	20ppm Max.
Frequency Stability	±75ppm~±150ppm
Operating Current	1μA Typ.
Power-supply Ramp	100ms Max.
Start-up Time at Power-up	180ms Typ.
Commercial Temperature	-10~+70°C
Industrial Temperature	-40~+85°C
Extended Industrial Temperature	-40~+105°C
Extended Cold Industrial Temperature	-55~+85°C
Automotive Temperature Range	-55~+105°C
Output Rise/Fall Time	200ns Max.
Output Clock Duty Cycle	48~52%
Voltage Vol (Max.) /Voh (Min.)	10%Vdd /90%Vdd
Maximum Output Drive	50pF Max.
Period Jitter	35ns Typ.
Storage Temperature	-65~+165°C
Aging (at 25°C)	±1ppm at First Year
Packing Unit	3000pcs./reel

Pin Functions

Top View

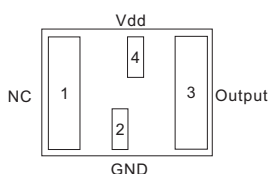

Pin Connections

Pin No.	SOT23-5 Pin	Connection
1	2, 3	NC /GND
2	1	GND
3	5	Output
4	4	Vcc

Dimensions [mm]

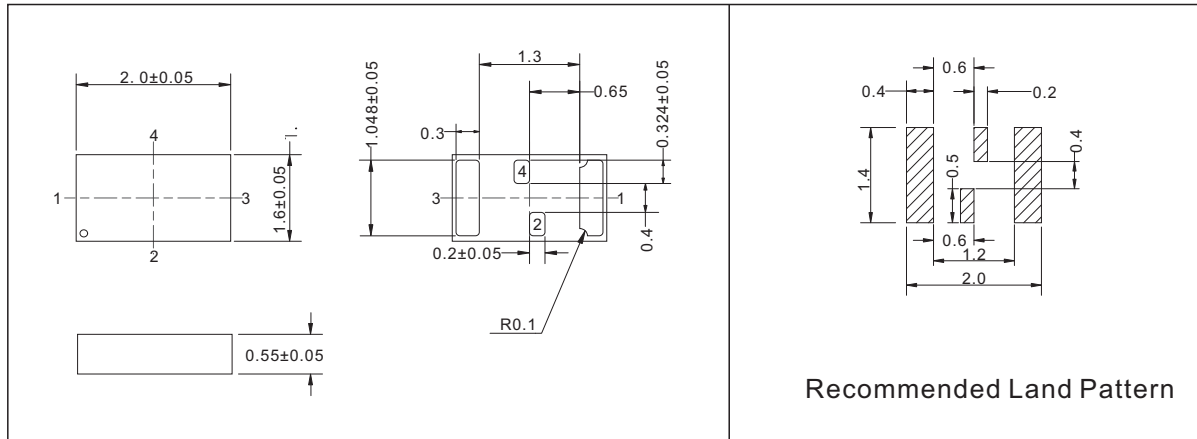

SJK8008 MEMS MHz Oscillator



Low Power Programmable Oscillator

Frequency: 1~110MHz

Features

- Frequency range from 1MHz to 110MHz
- Excellent frequency stability as low as $\pm 20\text{ppm}$
- Low power consumption of 3.5mA at 1.8V
- Standby mode for longer battery life
- Fast startup time of 5ms
- LVCMOS/HCMOS output type
- Size with 2.0×1.6, 2.5×2.0, 3.2×2.5, 5.0×3.2, 7.0×5.0 mm×mm
- Automatic mounting and reflow soldering
- Applications: DSC, Ethernet, USB, SATA, IP Cam, Tablets, E-books, etc
- RoHS Compliant /Pb Free

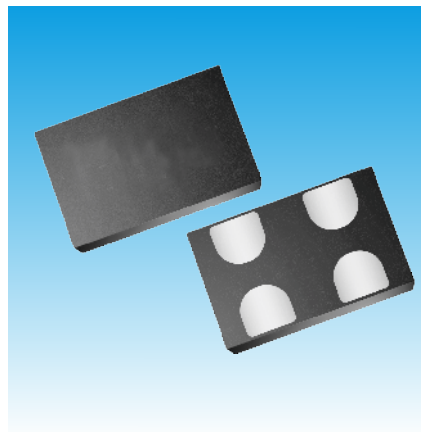

Standard Specification

Item /Type	SJK8008	
Output Type	LVCMOS/HCMOS	
Frequency Range	1~110MHz	
Supply Voltage	1.8V~3.3V	
Frequency Stability	$\pm 20\text{ppm} \sim \pm 50\text{ppm}$, or specify	
Current Consumption	4.5mA Max.	
Standby Current	4.3mA Max.	
OE Disable Current	4.2mA Max.	
Operating Temperature	-40~+85°C	
Duty Cycle	45~55%	
Rise/Fall Time	2.5ns Max.	
Voltage Vol (Max.)/Voh (Min.)	10% Vcc/90%Vcc	
Voltage Vil (Max.)/Vih (Min.)	30% Vcc/70% Vcc	
Input Pull-up Impedance	150K Ω Max. (Pin1 Logic High) 2M Ω Min. (Pin1 Logic Low)	
Start-up Time	5ms Max.	
Enable/Disable Time	130ns Max.	
Resume Time	5ms Max.	
RMS Period Jitter	3pS Max	
Peak to Peak Period Jitter	30pS Max.	
RMS Phase Jitter (12KHz~20MHz)	2pS Max.	
Storage Temperature	-65~+150°C	
Packing Unit	2016, 2520, 3225 size	3000pcs.Reel
	5032, 7050 size	1000pcs.Reel

Pin Functions

Top View

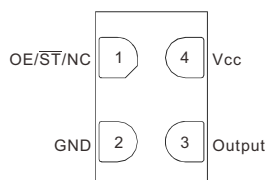

Pin Connections

Pin No.	Connection
1	OE /ST /NC
2	GND
3	Output
4	Vcc

SJK8009 MEMS MHz Oscillator



Low Power Programmable Oscillator Frequency: 115~137MHz

Features

- High frequency range from 115MHz to 137MHz
- Excellent frequency stability as low as $\pm 20\text{ppm}$
- Low power consumption of 4.9mA at 1.8V
- Standby mode for longer battery life
- Fast startup time of 5ms
- LVCMOS/HCMOS output type
- Size with 2.0×1.6, 2.5×2.0, 3.2×2.5, 5.0×3.2, 7.0×5.0 mm×mm
- Automatic mounting and reflow soldering
- Applications: GPON/EPON, Network switches, Routers, Server, Embedded systems, etc
- RoHS Compliant /Pb Free

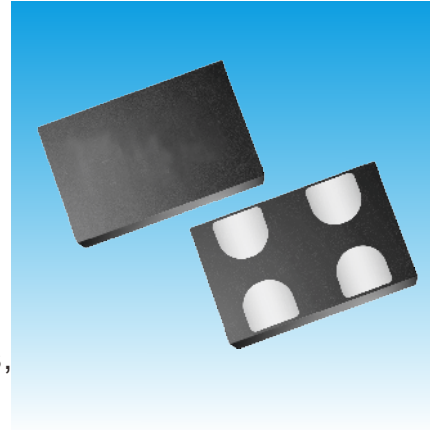

Standard Specification

Item /Type	SJK8009
Output Type	LVCMOS/HCMOS
Frequency Range	115~137MHz
Supply Voltage	1.8V~3.3V
Frequency Stability	$\pm 20\text{ppm} \sim \pm 50\text{ppm}$, or specify
Current Consumption	7.5mA Max.
Standby Current	4.3mA Max.
OE Disable Current	4.2mA Max.
Operating Temperature	-40~+85°C
Duty Cycle	45~55%
Rise/Fall Time	2.5ns Max.
Voltage Vol (Max.)/Voh (Min.)	10% Vcc/90%Vcc
Voltage Vil (Max.)/Vih (Min.)	30% Vcc/70% Vcc
Input Pull-up Impedance	150K Ω Max. (Pin1 Logic High)
	2M Ω Min. (Pin1 Logic Low)
Start-up Time	5ms Max.
Enable/Disable Time	122ns Max.
Resume Time	5ms Max.
RMS Period Jitter	4pS Max
Peak to Peak Period Jitter	30pS Max.
RMS Phase Jitter (12KHz~20MHz)	2pS Max.
Storage Temperature	-65~+150°C
Packing Unit	2016, 2520, 3225 size
	5032, 7050 size
	3000pcs.Reel
	1000pcs.Reel

Pin Functions

Top View

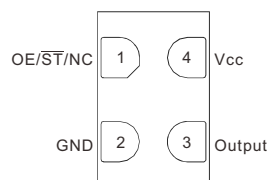

Pin Connections

Pin No.	Connection
1	OE /ST /NC
2	GND
3	Output
4	Vcc

Dimensions [mm]

Size: 2.0×1.6×0.75 mm

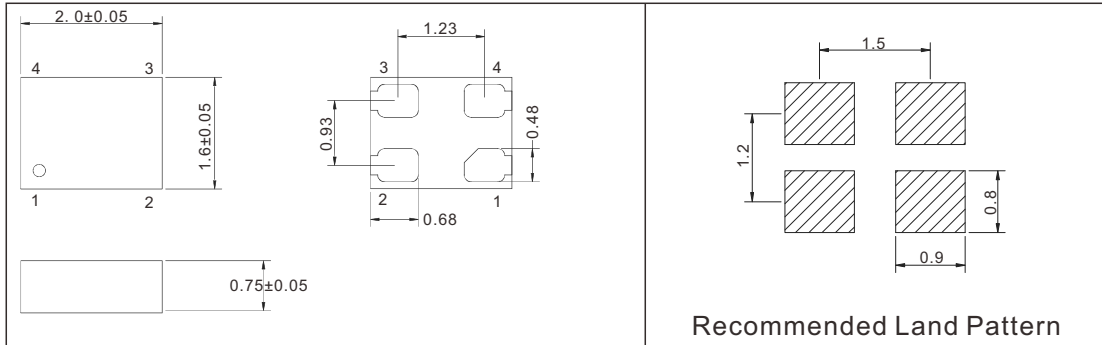

Size: 2.5×2.0×0.75 mm

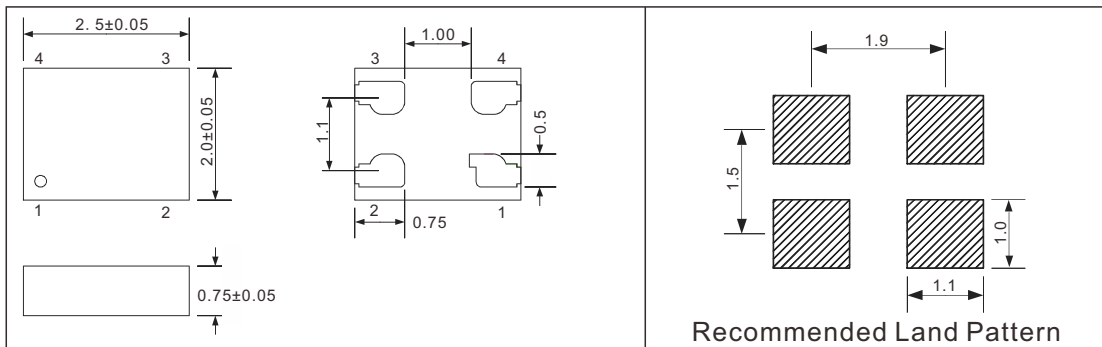

Size: 3.2×2.5×0.75 mm

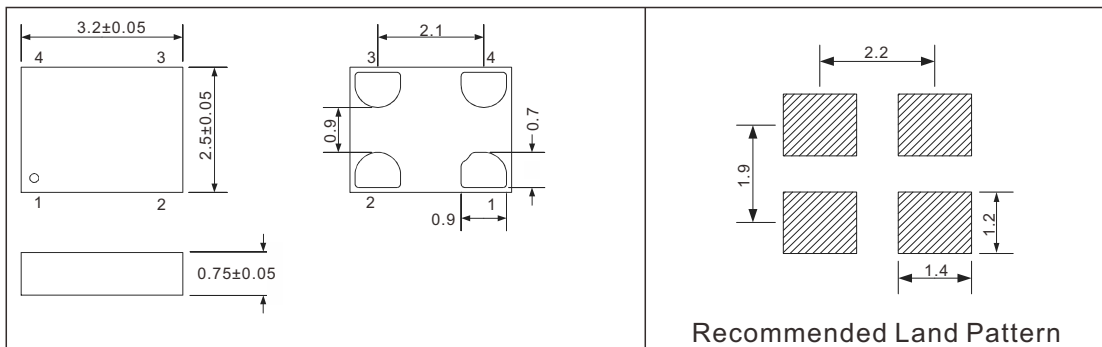

Size: 5.0×3.2×0.75 mm

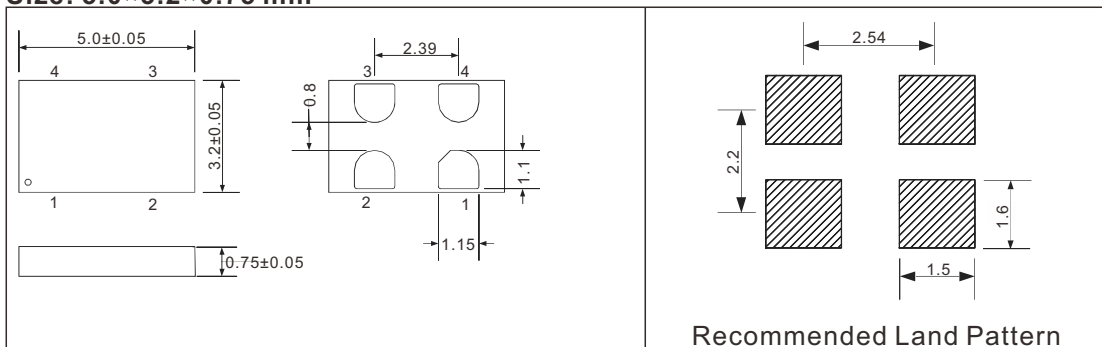

Size: 7.0×5.0×0.9 mm

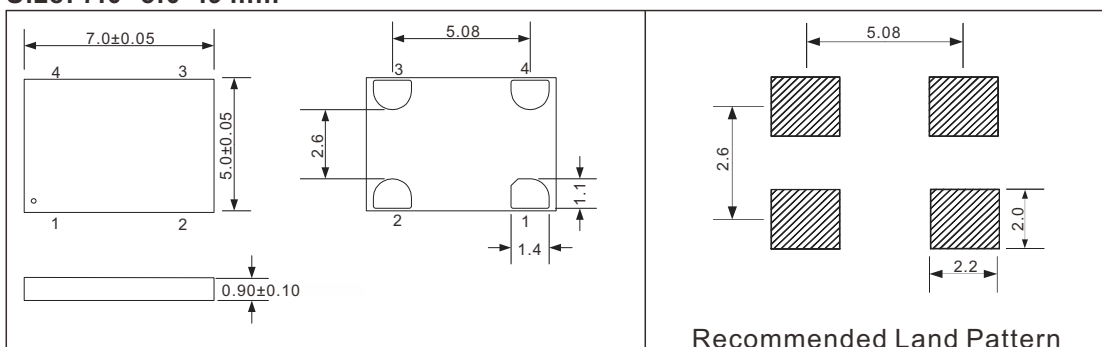

SJK9120 LVDS Output MEMS MHz Oscillator



LVDS Output MEMS Oscillator

Frequency: 25~212.5MHz

Features

- Output frequency range from 25MHz to 212.5MHz
- Excellent frequency stability as low as ± 10 ppm
- 0.6ps RMS phase jitter over 12KHz to 20MHz
- Industrial and extended commercial temperature range.
- LVDS output signaling types
- Size with 3.2×2.5, 5.0×3.2, 7.0×5.0, mm×mm
- Automatic mounting and reflow soldering
- Applications: 10G Ethernet, SONET, SATA, SAS, Telecom, Storage, Server, etc
- RoHS Compliant /Pb Free

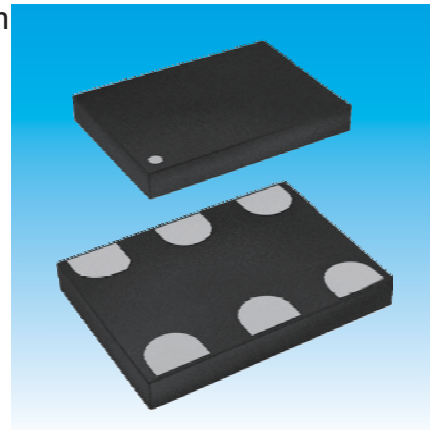

Standard Specification

Item /Type	SJK9120	
Output Type	LVDS	
Frequency Range	25~212.5MHz	
Supply Voltage	2.5V/3.3V/2.25~3.63V	
Frequency Stability	± 10 ppm~ ± 50 ppm, or specify	
Operating Temperature	-40~+85°C, -20~+70°C	
Input Voltage High (VIH)	70%Vdd	
Input Voltage Low (VIL)	30%Vdd	
Input Pull-up Impedance	250K Ω Max. (Pin1 Logic High) 2M Ω Min. (Pin1 Logic Low)	
Start-up Time	10ms Max.	
Resume Time	10ms Max.	
Duty Cycle	45~55%	
Current Consumption	55mA Max.	
OE Disable Supply Current	35mA Max.	
Differential Output Voltage	450mV Max.	
Output Disable Leakage Current	1 μ A Max.	
Standby Current	100 μ A Max.	
VOD Magnitude Change	50mV	
Offset Voltage	1.375V Max.	
VOS Magnitude Change	50mV Max.	
Rise/Fall Time	600ps Max.	
OE Enable/Disable Time	115ns Max.	
RMS Period Jitter	1.7pS Max.	
RMS Period Jitter (Random)	0.85pS Max.	
Storage Temperature Range	-65~150°C	
Packing Unit	3.2×2.5mm	3000pcs.Reel
	7.0×5.0, 5.0×3.2mm	1000pcs.Reel

SJK9120 LVPECL Output MEMS MHz Oscillator

LV-PECL Output MEMS Oscillator Frequency: 25~212.5MHz

Features

- Output frequency range from 25MHz to 212.5MHz
- Excellent frequency stability as low as ± 10 ppm
- 0.6ps RMS phase jitter over 12KHz to 20MHz
- Industrial and extended commercial temperature range.
- LVPECL output signaling types
- Size with 3.2×2.5, 5.0×3.2, 7.0×5.0 mm×mm
- Automatic mounting and reflow soldering
- Applications: 10G Ethernet, SONET, SATA, SAS, Telecom, Storage, Server, etc
- RoHS Compliant /Pb Free

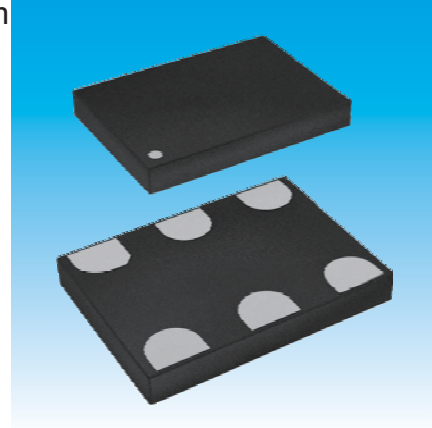

Standard Specification

Item /Type	SJK9120	
Output Type	LVPECL	
Frequency Range	25~212.5MHz	
Supply Voltage	2.5V/3.3V/2.25~3.63V	
Frequency Stability	± 10 ppm~ ± 50 ppm, or specify	
Operating Temperature	-40~+85°C, -20~+70°C	
Input Voltage High (VIH)	70%Vdd	
Input Voltage Low (VIL)	30%Vdd	
Input Pull-up Impedance	250K Ω Max. (Pin1 Logic High) 2M Ω Min. (Pin1 Logic Low)	
Start-up Time	10ms Max.	
Resume Time	10ms Max.	
Duty Cycle	45~55%	
Current Consumption	69mA Max.	
OE Disable Supply Current	35mA Max.	
Output Disable Leakage Current	1 μ A Max.	
Standby Current	100 μ A Max.	
Maximum Output Current	30mA Max.	
Output High Voltage (VOH)	Vdd-1.1V	
Output Low Voltage (VOL)	Vdd-1.9V	
Output Differential Voltage Swing	2.0V Max.	
Rise/Fall Time	500ps Max.	
OE Enable/Disable Time	115ns Max.	
RMS Period Jitter	1.7pS Max.	
RMS Period Jitter (Random)	0.85pS Max.	
Storage Temperature Range	-65~150°C	
Packing Unit	3.2×2.5mm	3000pcs.Reel
	7.0×5.0, 5.0×3.2mm	1000pcs.Reel

Features

- Any frequency between 1MHz to 220MHz accurate to 6 decimal place
- LVDS output signaling type
- 0.6ps RMS phase jitter (random) over 12KHz to 20MHz bandwidth
- Industrial and extended commercial temperature range
- Size with 3.2×2.5, 5.0×3.2, 7.0×5.0, mm×mm
- Automatic mounting and reflow soldering
- Applications: 10G Ethernet, SONET, SATA, SAS, Telecom, Storage, Server, etc
- RoHS Compliant /Pb Free

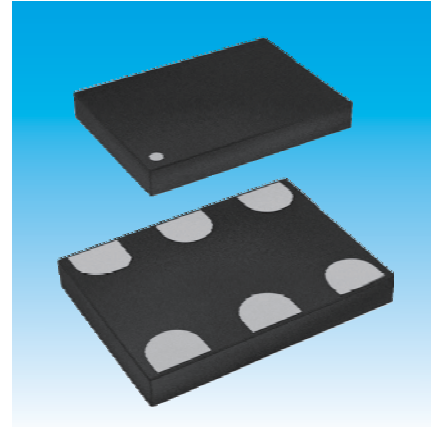

Standard Specification

Item /Type	SJK9121	
Output Type	LVDS	
Frequency Range	1~220MHz	
Supply Voltage	2.5V/3.3V/2.25~3.63V	
Frequency Stability	±10ppm~±50ppm, or specify	
Operating Temperature	-40~+85°C, -20~+70°C	
Input Voltage High (VIH)	70%Vdd	
Input Voltage Low (VIL)	30%Vdd	
Input Pull-up Impedance	250KΩ Max. (Pin1 Logic High) 2MΩ Min. (Pin1 Logic Low)	
Start-up Time	10ms Max.	
Resume Time	10ms Max.	
Duty Cycle	45~55%	
Current Consumption	55mA Max.	
OE Disable Supply Current	35mA Max.	
Differential Output Voltage	450mV Max.	
Output Disable Leakage Current	1μA Max.	
Standby Current	100μA Max.	
VOD Magnitude Change	50mV	
Offset Voltage	1.375V Max.	
VOS Magnitude Change	50mV Max.	
Rise/Fall Time	700ps Max.	
OE Enable/Disable Time	115ns Max.	
RMS Period Jitter	1.7pS Max.	
RMS Period Jitter (Random)	0.85pS Max.	
Storage Temperature Range	-65~150°C	
Packing Unit	3.2×2.5mm	3000pcs.Reel
	7.0×5.0, 5.0×3.2mm	1000pcs.Reel

Features

- Any frequency between 1MHz to 220MHz accurate to 6 decimal place
- LVPECL output signaling type
- 0.6ps RMS phase jitter (random) over 12KHz to 20MHz bandwidth
- Industrial and extended commercial temperature range
- Size with 3.2×2.5, 5.0×3.2, 7.0×5.0, mm×mm
- Automatic mounting and reflow soldering
- Applications: 10G Ethernet, SONET, SATA, SAS, Telecom, Storage, Server, etc
- RoHS Compliant /Pb Free

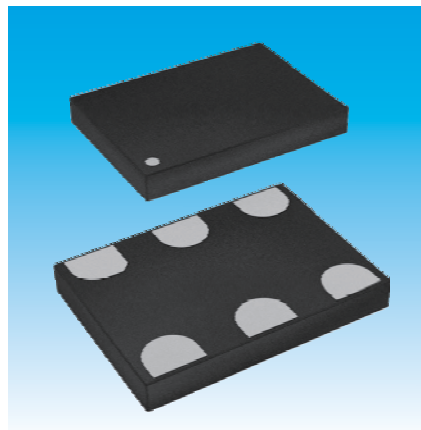

Standard Specification

Item /Type	SJK9121	
Output Type	LVPECL	
Frequency Range	1~220MHz	
Supply Voltage	2.5V/3.3V/2.25~3.63V	
Frequency Stability	±10ppm~±50ppm, or specify	
Operating Temperature	-40~+85°C, -20~+70°C	
Input Voltage High (VIH)	70%Vdd	
Input Voltage Low (VIL)	30%Vdd	
Input Pull-up Impedance	250KΩ Max. (Pin1 Logic High) 2MΩ Min. (Pin1 Logic Low)	
Start-up Time	10ms Max.	
Resume Time	10ms Max.	
Duty Cycle	45~55%	
Current Consumption	69mA Max.	
OE Disable Supply Current	35mA Max.	
Output Disable Leakage Current	1μA Max.	
Standby Current	100μA Max.	
Maximum Output Current	30mA Max.	
Output High Voltage (VOH)	Vdd-1.1V	
Output Low Voltage (VOL)	Vdd-1.9V	
Output Differential Voltage Swing	2.0V Max.	
Rise/Fall Time	700ps Max.	
OE Enable/Disable Time	115ns Max.	
RMS Period Jitter	1.7pS Max.	
RMS Period Jitter (Random)	0.85pS Max.	
Storage Temperature Range	-65~150°C	
Packing Unit	3.2×2.5mm	3000pcs.Reel
	7.0×5.0, 5.0×3.2mm	1000pcs.Reel

Differential Output MEMS Oscillator Dimensions

Pin Functions

Top View

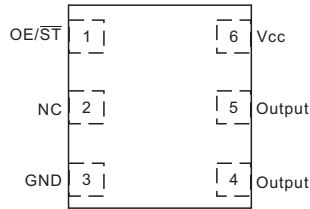

Pin Connections

Pin No.	Connection
1	OE/ST
2	NC
3	GND
4	Output (Oscillator Output)
5	Output (Complementary Oscillator Output)
6	Vcc

Dimensions [mm]

Size: 3.2×2.5×0.75 mm

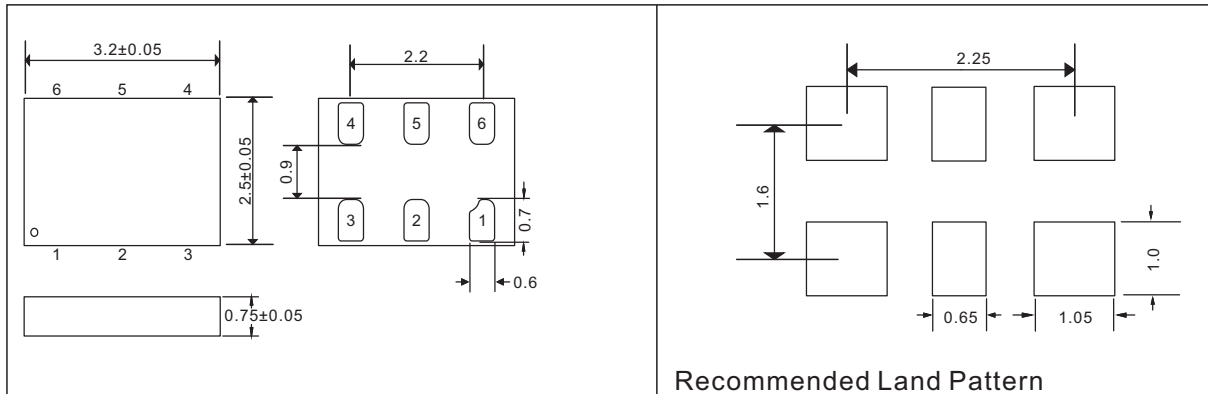

Size: 5.0×3.2×0.75 mm

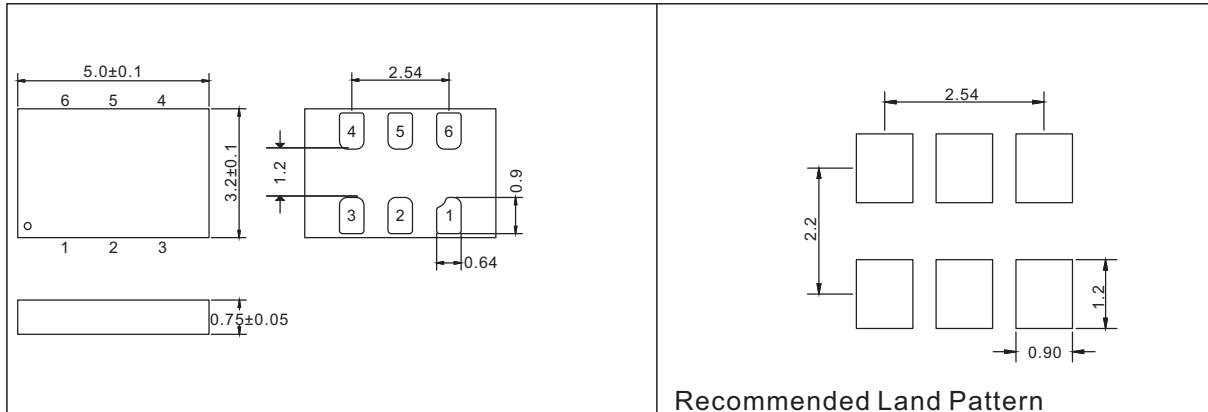

Size: 7.0×5.0×0.9 mm

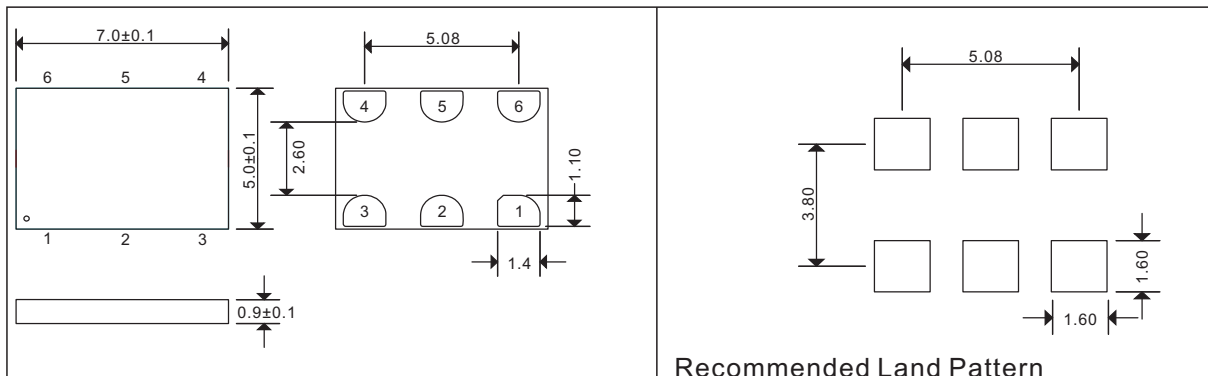

SJK8918 High Temperature MHz MEMS Oscillator



High Temperature MHz MEMS Oscillator Output Frequency: 1~110MHz

Features

- Output frequency range from 1MHz to 110MHz
- Excellent total frequency stability as low as ± 20 ppm
- Operating temperature from -40°C to 125°C
- Supply voltage of 1.8V or 2.5V to 3.3V
- Low power consumption of 3.5 mA typical
- LVCMOS/LVTTL compatible output
- Size with 2.0×1.6, 2.5×2.0, 3.2×2.5, 5.0×3.2, 7.0×5.0 mm×mm
- Automatic mounting and reflow soldering
- Applications: GPON/EPON, Network switches, Routers, Server, Embedded systems, etc
- RoHS Compliant /Pb Free

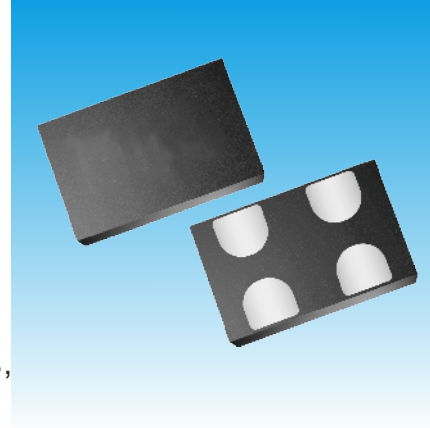

Standard Specification

Item /Type	SJK8918
Output Type	LVCMOS/HCMOS
Frequency Range	1~110MHz
Supply Voltage	1.8V~3.3V
Frequency Stability	$\pm 20\text{ppm} \sim \pm 50\text{ppm}$, or specify
Current Consumption	4.7mA Max.
Standby Current	8.5mA Max.
OE Disable Current	4.5mA Max.
Operating Temperature	$-40 \sim +105^{\circ}\text{C}$ / $-40 \sim +125^{\circ}\text{C}$
Duty Cycle	45~55%
Rise/Fall Time	2.5ns Max.
Voltage Vol (Max.)/Voh (Min.)	10% Vcc/90%Vcc
Voltage Vil (Max.)/Vih (Min.)	30% Vcc/70% Vcc
Input Pull-up Impedance	150K Ω Max. (Pin1 Logic High)
	2M Ω Min. (Pin1 Logic Low)
Start-up Time	5ms Max.
Enable/Disable Time	130ns Max.
Resume Time	5ms Max.
RMS Period Jitter	3pS Max
Peak to Peak Period Jitter	25pS Max.
RMS Phase Jitter (12KHz~20MHz)	2pS Max.
Storage Temperature	$-65 \sim +150^{\circ}\text{C}$
Packing Unit	2016, 2520, 3225 size
	5032, 7050 size
	3000pcs.Reel
	1000pcs.Reel

Pin Functions

Top View

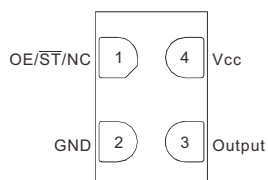

Pin Connections

Pin No.	Connection
1	OE /ST /NC
2	GND
3	Output
4	Vcc

Dimensions [mm]

Size: 2.0×1.6×0.75 mm

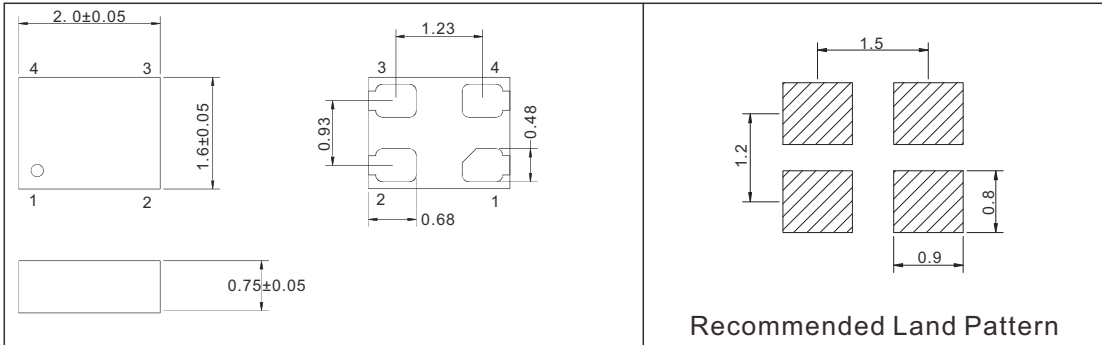

Size: 2.5×2.0×0.75 mm

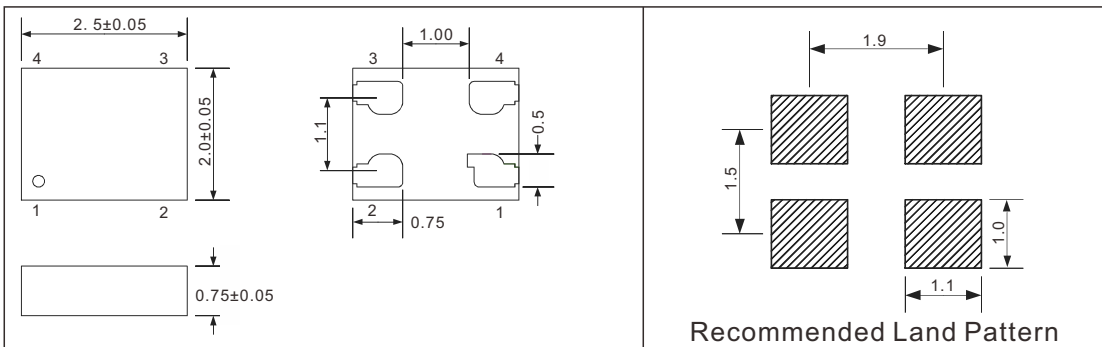

Size: 3.2×2.5×0.75 mm

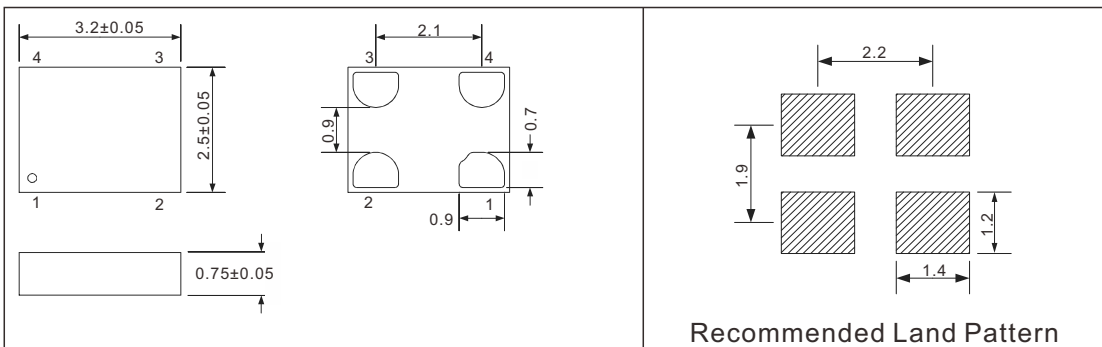

Size: 5.0×3.2×0.75 mm

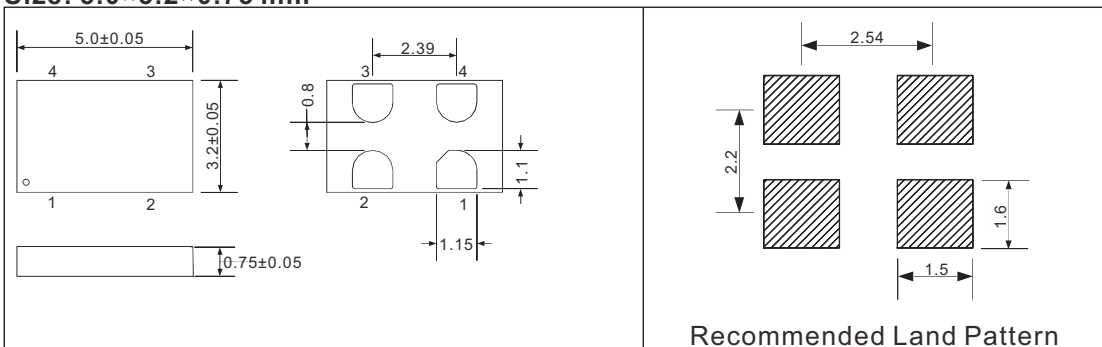

Size: 7.0×5.0×0.9 mm

