

TCXO / Temperature Compensated Crystal Oscillator

7Q Series SMD 2520 TCXO/VC-TCXO

10MHz~60MHz

O: Clipped Sine Wave

Size: 2.5×2.0×0.7 mm

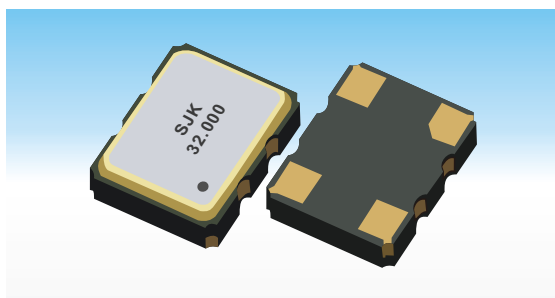

Actual size

Features

- 2520 size ultra miniature and lightweight SMD TCXO /VC-TCXO
- Low voltage operation
- Single package structure
- High frequency range: 16MHz~60MHz
- Low phase noise
- Application for GPS /GNSS, Mobile phone, Wearable device, IoT, Telecommunications, Industrial radio communications, etc
- RoHS Compliant /Pb Free



Standard Specifications

Item	Type	7Q Series SMD 2520 TCXO /VC-TCXO
Output Level		0.8Vp-p (Clipped Sine Wave/DC-coupled)
Output Load		10KΩ//10pF
Frequency Range		10MHz~60MHz
Supply Voltage		1.8V /2.5V /2.8V /3.0V /3.3V
Current Consumption		2.0mA max.
Stand-by Current		3μA max.
Frequency Stability	vs. Tolerance	±2.0ppm max. (After 2 reflows)
	vs. Temperature	±0.5ppm~±2.5ppm max.
	vs. Supply Voltage	±0.2ppm max. (Vcc±5%)
	vs. Load Variation	±0.2ppm max. (10KΩ//10pF±5%)
	vs. Aging	±1.0ppm max./year
Start-up Time		2.0ms max.
VC-TCXO	Frequency Control Range	±5.0ppm min.
	Control Voltage Range	0.9V±0.6V@Vcc=1.8V, 1.4V±1V@Vcc>=2.6V, 1.5V±1V@Vcc>=3.0V
	Input impedance	1MΩ min.
	Response Slope	Postivie
Phase Noise @19.2MHz	Offset 10Hz	-80dBc/Hz
	Offset 100Hz	-115dBc/Hz
	Offset 1KHz	-135dBc/Hz
	Offset 10KHz	-148dBc/Hz
Operating Temperature Range		-30~+85°C, -40~+85°C, or specify
Storage Temperature Range		-55~+125°C

Dimensions

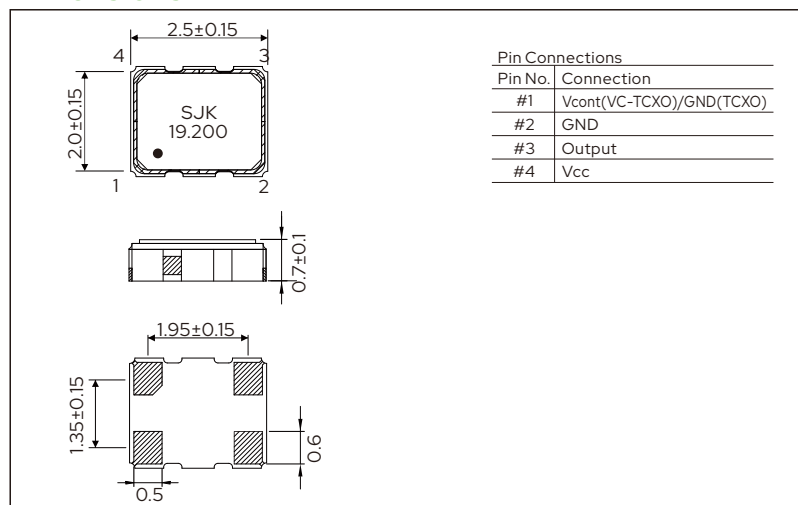

Recommended Land Pattern [mm]

